

ultraframe

Transforming light and space

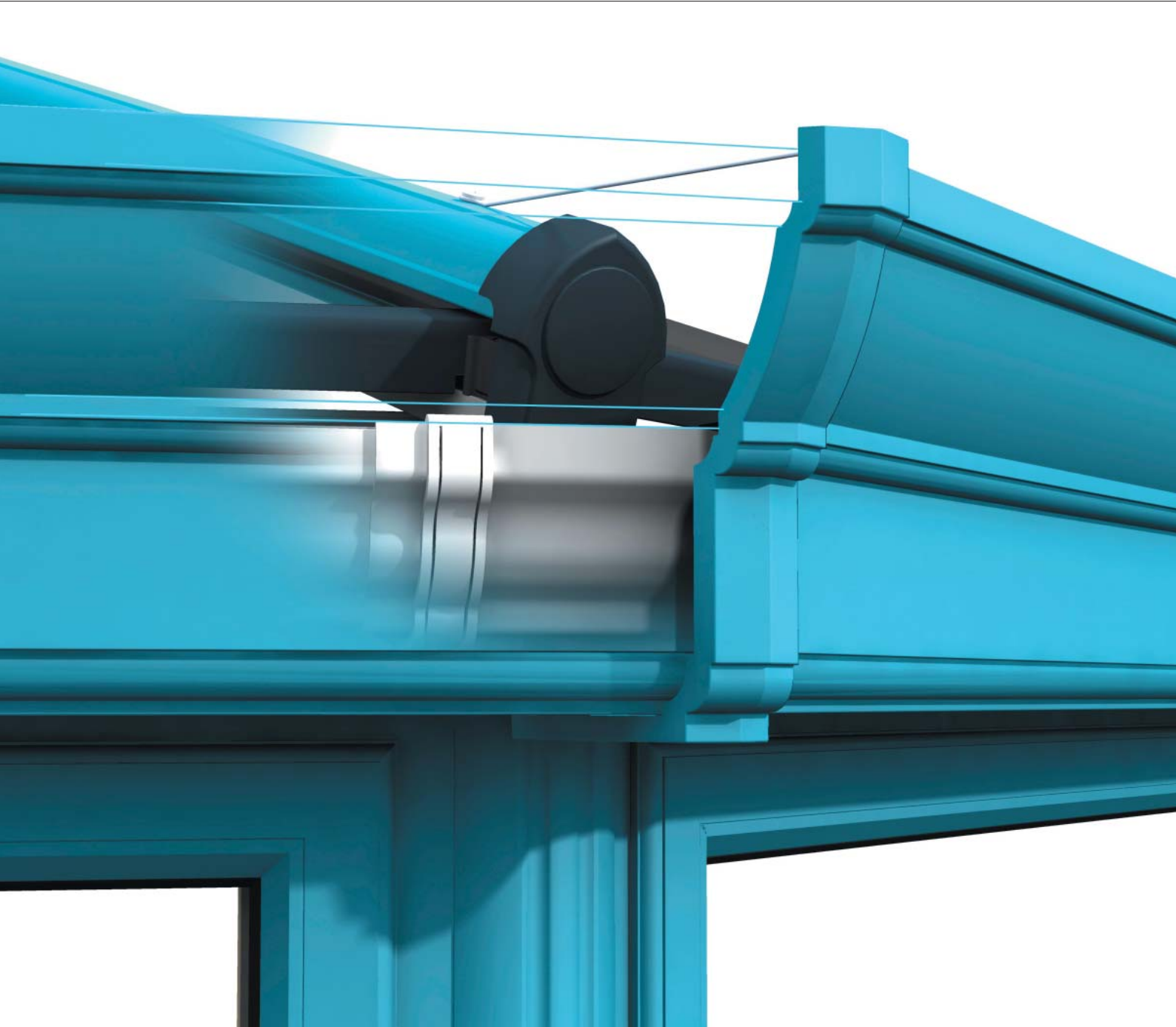

Window & Door Products

Orangery

Home Extension Products

Conservatory Products

Skylight Products

Classic **Cornice**

Installation Guide

Version 2.0 | January 2013

PRODUCT IDENTIFICATION

Recommended tools - Long reach magnetic bit, 73mm hole saw

Additional materials - Timber baton (treated) 49mm x 20mm and cut to length as required - only used when a gutter return and the host wall is required.

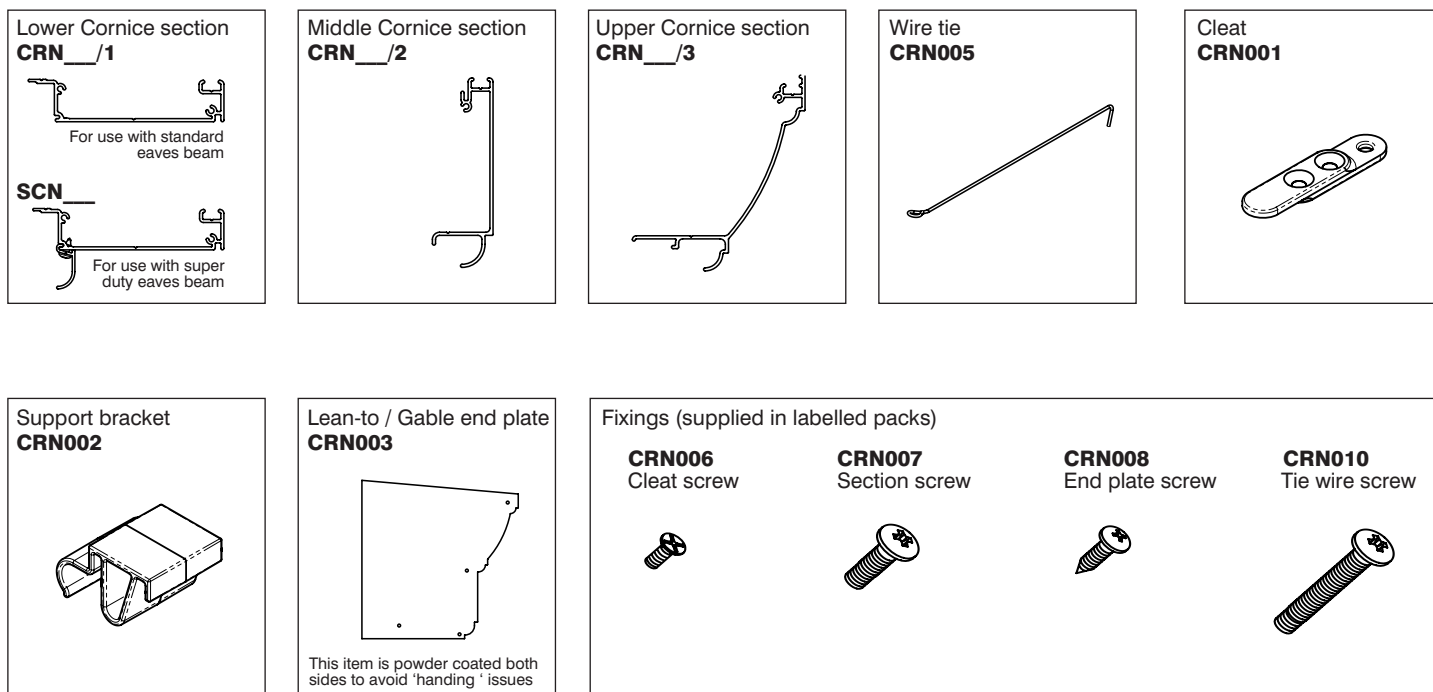

PRE INSTALLATION INFORMATION

FILM - Peel back the protective film at each of the mitred corners, prior to fitting. Ensure all film is removed following installation. Failure to do so will damage the finish over time.

SEALING - After installation, do not seal around the down pipe hole (step 1). The gap will allow water to escape from Cornice in the event of extreme weather conditions.

LADDERS - Take care when using ladders as they could damage the Cornice gutter.

PLEASE PASS THIS INFORMATION ON TO THE HOMEOWNER

FITTERS TIPS

1. Start the installation of Cornice when the basic roof structure is in place (bars and ridge) but before the glazing and guttering have been installed.
2. Prior to installation please ensure the eaves beam joints are tight. Any gaps could translate through to the Cornice mitres.
3. Try temporarily fixing the lower Cornice sections, position appropriately to obtain the best mitre fit. Remember the lower Cornice section is the datum!
4. Do not force the cleats during assembly. Cleats are used to position the mitre joints only!

For on site assistance contact the Technical Support Team on 0843 208 6953 or email techsupport@ultraframe.co.uk

CORNICE INSTALLATION

Ensure the eaves beam, glazing bars, ridge/wallplate are already installed

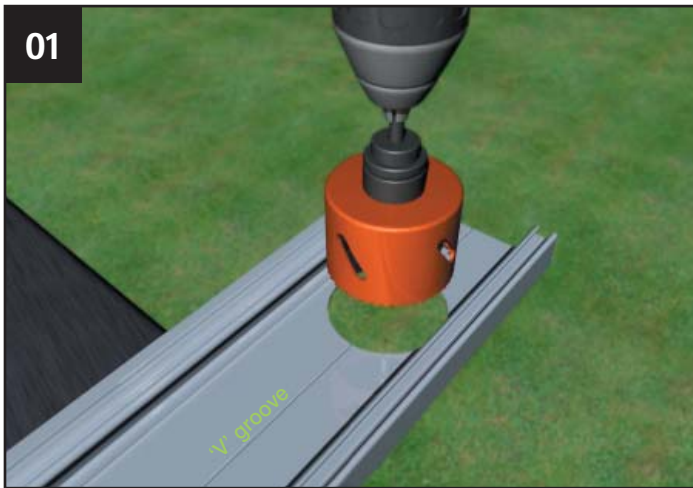

Decide the position of the gutter outlet by lining the extrusion 'v' groove up with the centre of the hole for the down pipe. Using a 73mm dia hole saw, cut the hole for the down pipe in the lower section.

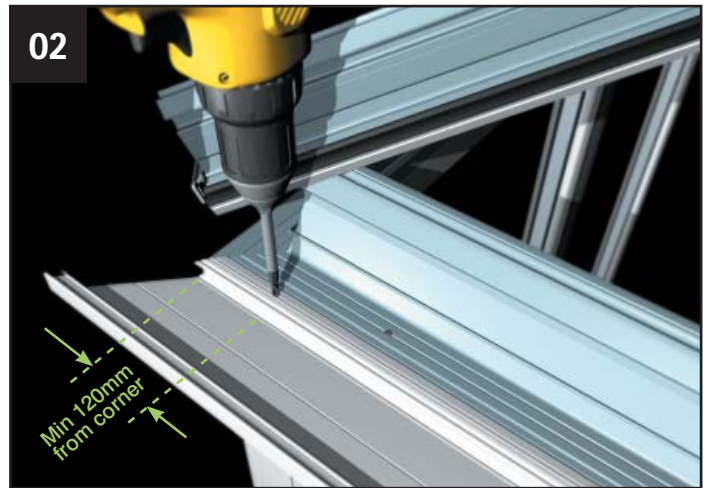

Remove the under gutter trim and dispose of it. Prior to fitting gutter offer up the lower Cornice section then secure into position using the fixings provided (CRN007). **Please note: Always start with the front facet!**



Fit the cleats (CRN001) to the desired side using the fixings provided (CRN006) as shown and assemble the remaining lower sections

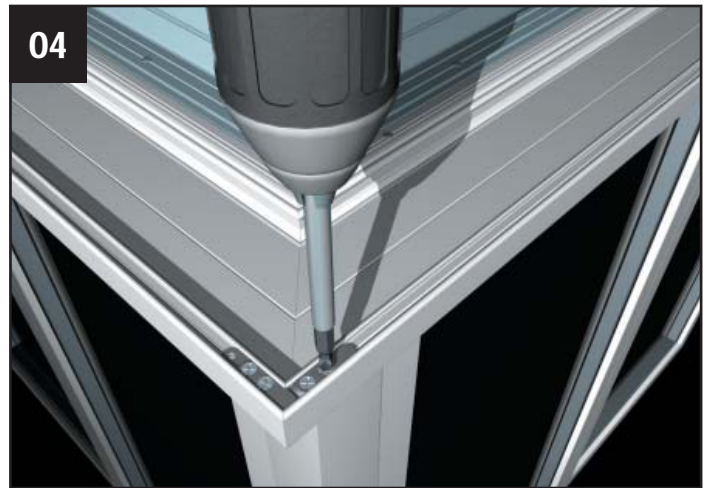

Secure each corner using the cleats (CRN001) and fixings provided (CRN006).

The gutter and glazing should now be fitted (see main guide). Check integrity of all gutter joints before proceeding further.

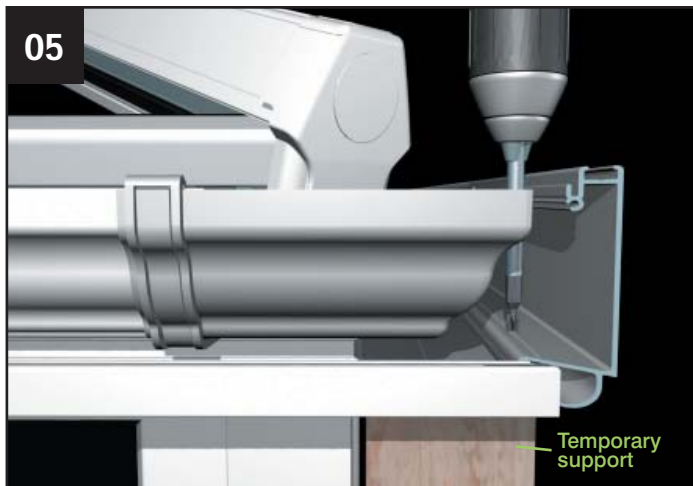

Offer up the middle Cornice section into position, (it may be advisable to temporarily support the lower Cornice section whilst fixing) secure using fixings provided (CRN007). (Long reach driver required).

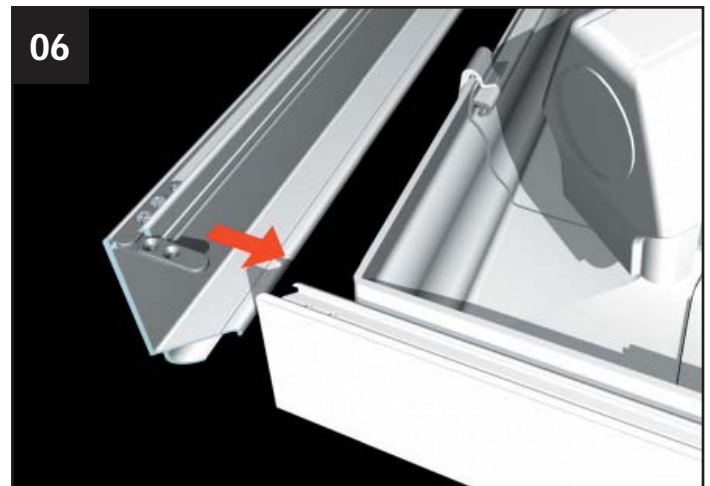

Fit cleats as shown in step 3. Offer up the next middle Cornice section. Continue to support lower section as shown in step 5.

CORNICE INSTALLATION

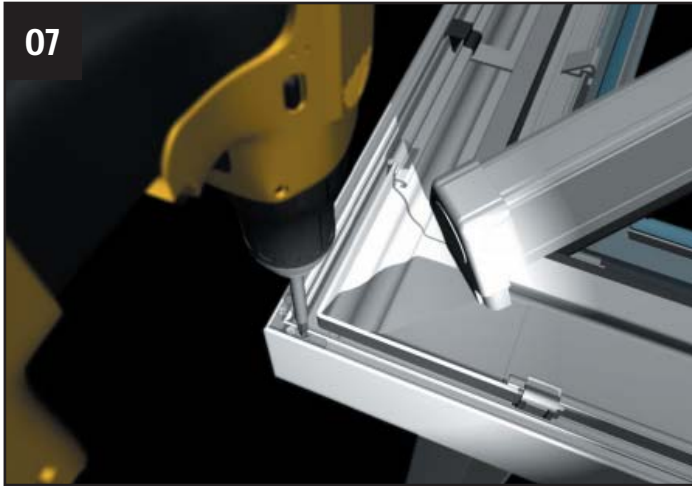

As shown in step 5 it may be advisable to temporarily support the Cornice whilst fixing. Secure corners using the cleats (CRN001) and fixings provided (CRN006).

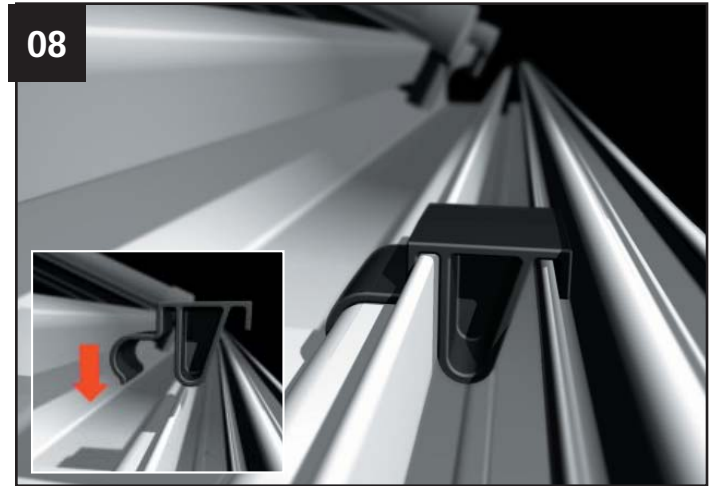

Clip fit the support brackets (CRN002), adjacent to every gutter bracket.



Temporarily support and fit the upper Cornice section, using the fixings provided (CRN007). Secure the corners using the cleat (CRN001) and fixings (CRN006) as shown in step 3.



Secure the upper Cornice section using the wire ties at each glazing bar. Hook the wire tie into the pre-drilled hole in the upper Cornice section and screw fix into the glazing bar, ensuring the upper section remains parallel to the frames/roof line.

CORNICE CORNER INSTALLATION

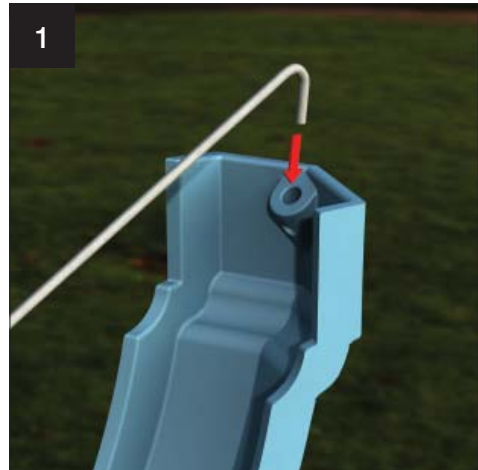
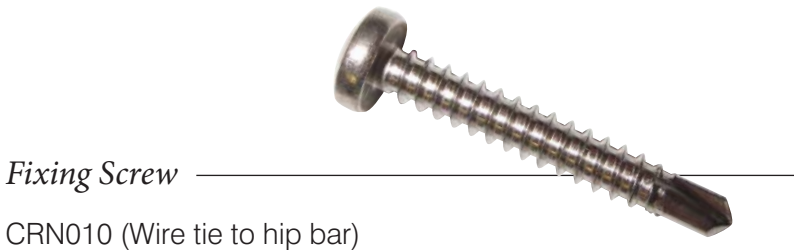
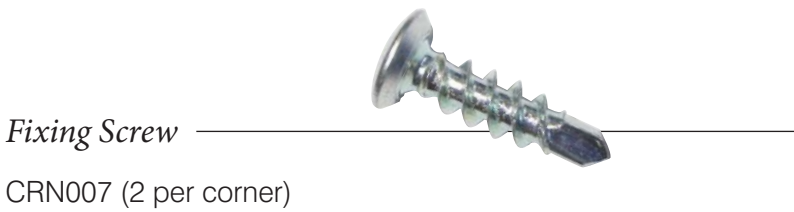
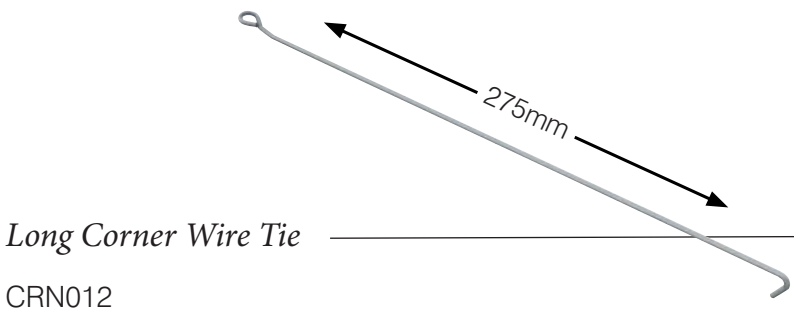
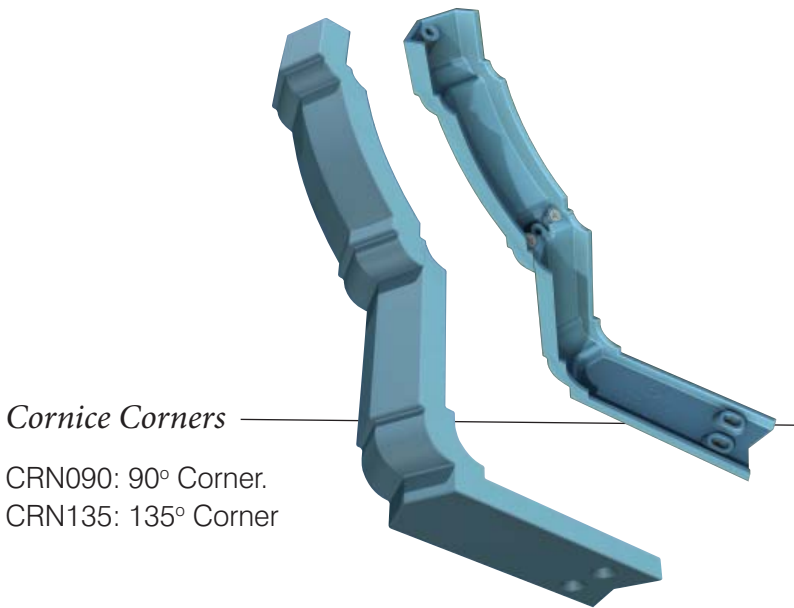

1. Prior to fitting the corner insert the special longer wire tie CRN012, into the corner as indicated



2. Whilst ensuring that the corner remains located in position, screw fix using self drilling screws CRN007

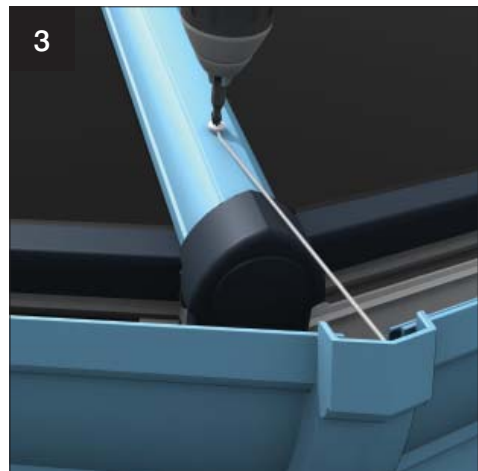

3. Finally secure the corner by screw fixing the wire tie to the glazing bar using self drilling screw CRN010

Please note that it is not compulsory to fit the corners. If a crisp sharp mitre is required the corners need not be fitted, provided due care has been taken during installation. If on the other hand the 'look' of the cast corner is preferred follow the instructions above for each relevant corner. Corners will be supplied for the 135° & 90° external corners. Other angles, straight joints or internal mitres do not currently enjoy the benefits of a jointer.

CORNICE INSTALLATION - ADDITIONAL DETAILS



Ensure the treated timber baton (49mm x 20mm) is level, then fix into position.



Secure lower section using fixings provided (CRN007)

Gutter stop end detail

Used with lean-to roofs, gable roofs or when then gutter returns along the host wall

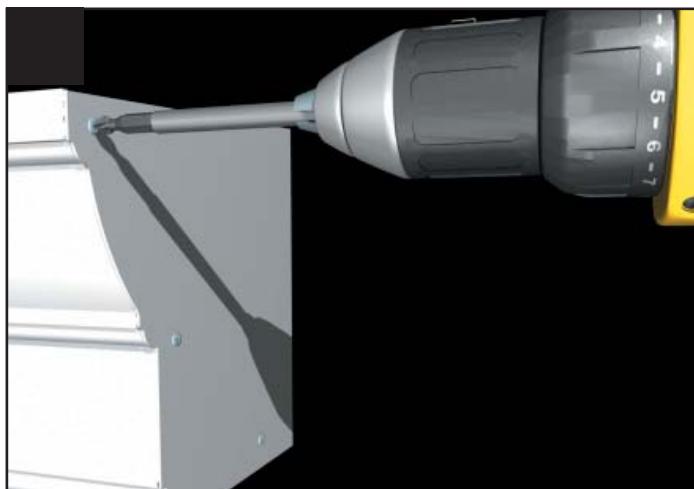

Secure the end plate into position using the fixings provided (CRN008).

Cornice & victorian boxgutter detail

For situations other than that shown, Cornice should be prepped by you on site to suit the wall condition you find.

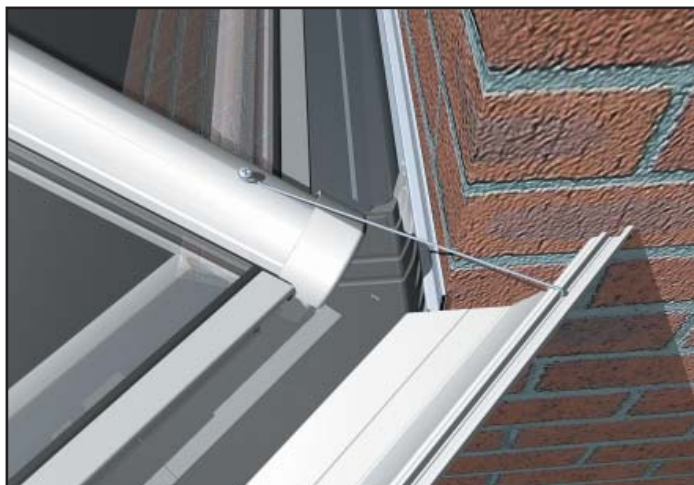

CORNICE INSTALLATION - ADDITIONAL DETAILS

Cornice & gable eaves beam detail

Used on lean-to styles with raked frames or duo-pitch gables that use the gable support beam

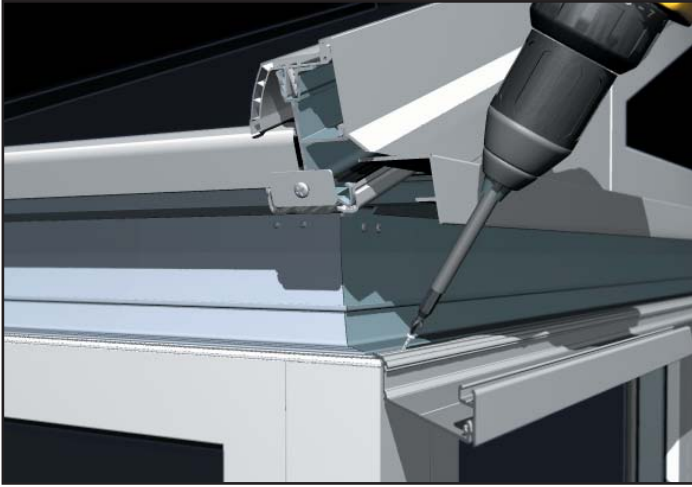

Fix lower section as shown - continue with the remainder

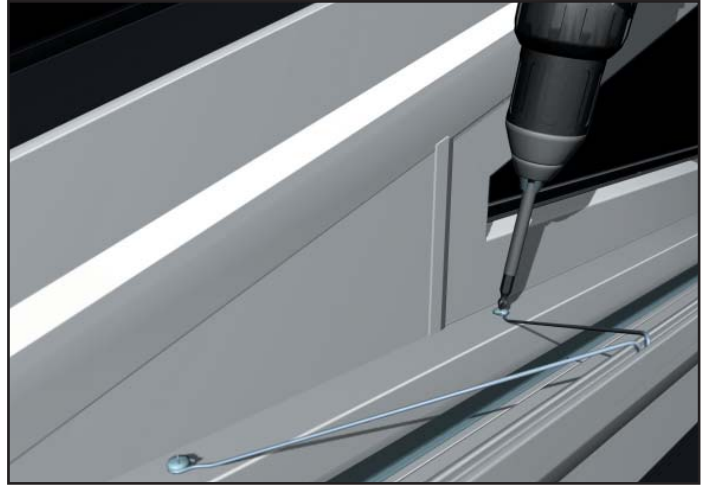

Fix wire ties at an angle as shown, ensure the Cornice is parallel to the frames/roof line.

Cornice & fly through gutter detail

Used when the gutter extends beyond the Cornice.



Take the end plate (CRN003) and cut to the shape of the gutter that projects beyond the Cornice.

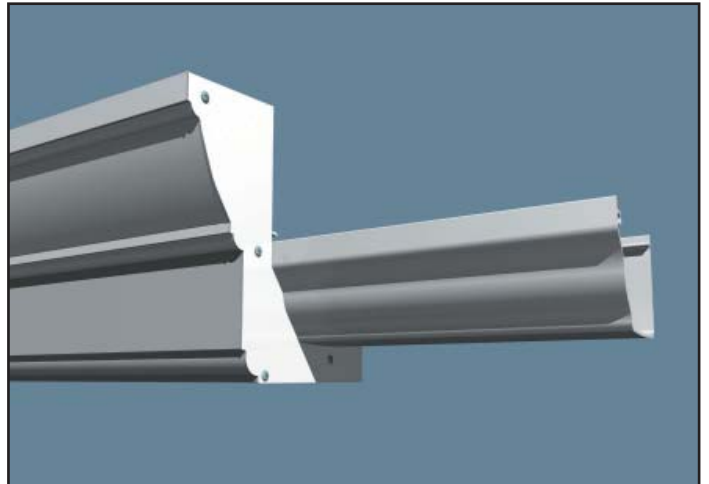

Typical finished detail.

CORNICE INSTALLATION - INLINE OUTLET COVER

IT IS IMPORTANT TO CONSIDER THE OUTLET POSITION PRIOR TO FITTING THE CORNICE. WHEN THE OUTLET POSITION HAS BEEN DECIDED NOTCH THE CORNICE LOWER PROFILE AS SHOWN

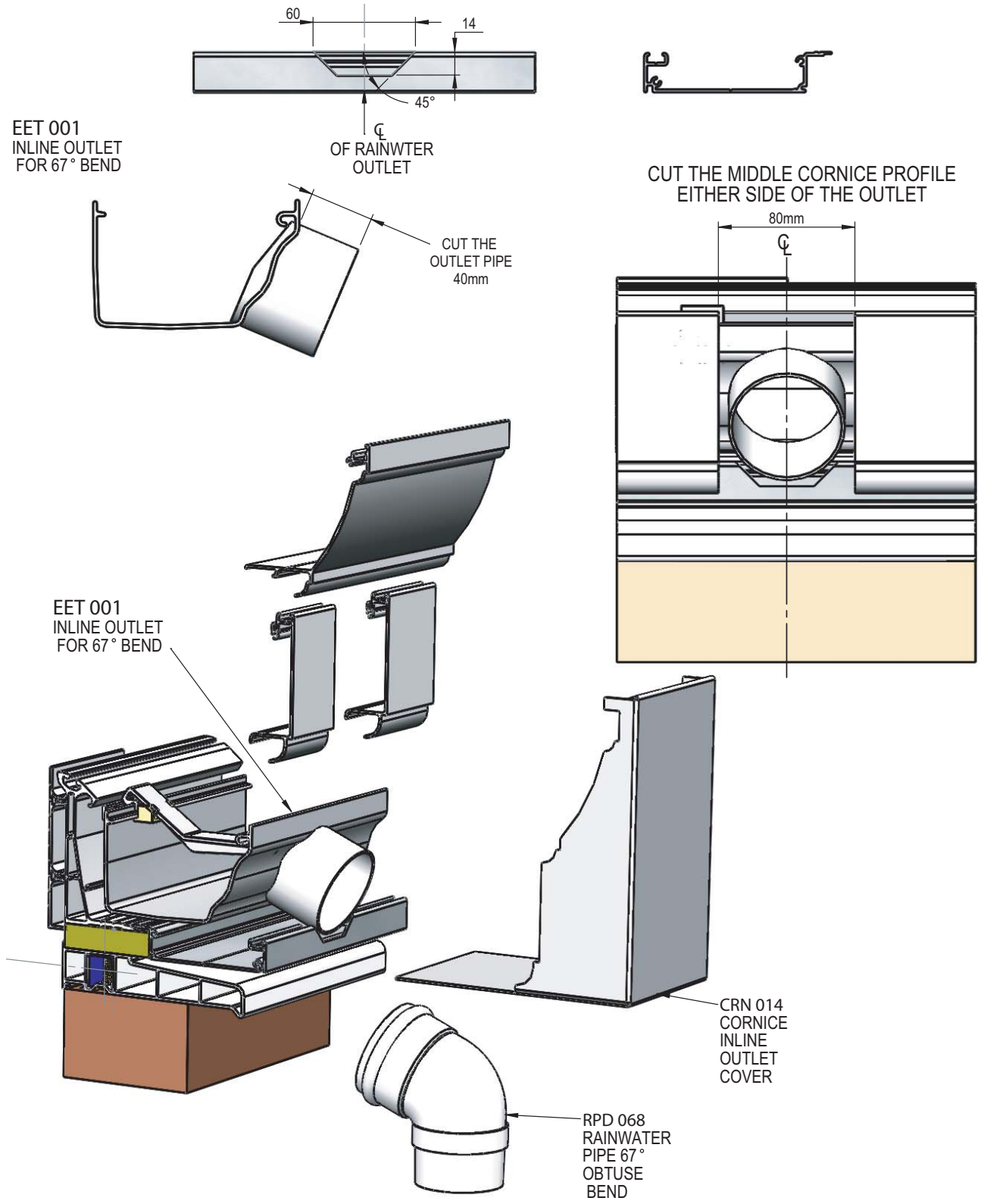

It is Ultraframe's policy to continually seek to improve its products, processes and services, and we reserve the right to change specifications without prior notice. Ultraframe is a trading name of Ultraframe (UK) Limited. Job No.: 2192 CRN020 TBC 12/12